

Consideration of the Cause of Inverter Noise called Ringing

(This report was presented by author at 249th American Chemical Society National Meeting & Exposition at Denver in March 24, 2015, ENFL 351.)

Osamu Ide,
Takao Yamazaki (Ph.D.),
Takashi Maeza,
Takayuki Funabashi, and
Honami Ichinose

Clean Energy Research Laboratory,
3-4-21-601 Mita, Minato-ku, Tokyo, 108-0073, Japan,
03-5442-4746 (fax) daphne@myad.jp (email)

EXPERIMENTAL CIRCUIT

The experimental circuit is shown in Fig.1. The current from DC Power Supply is turned on and off by a MOS-Transistor as input to the primary coil of the transformer. The driving pulse width (T_a) is around 2 μ sec. The added capacitance (C_a) is connected across to the primary coil. The secondary coil of the transformer is connected to the load resistance R_1 (500 Ω). After the transistor is turned on, the input current waveform to the primary coil is measured by the digital oscilloscope at 100MHz sampling frequency. Figure 2a shows the waveforms with no extra capacitor and Figure 2b, 2c shows the waveforms with added capacitor. The results are then plotted by X-Y plotter.

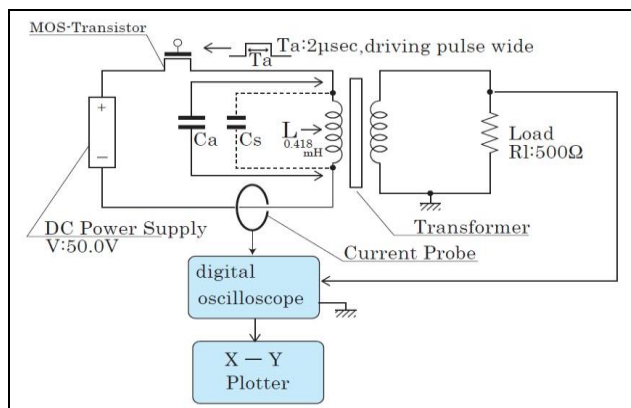

Figure 1. Experimental circuit

EXPERIMENTAL RESULTS

Figure 2(a) shows the Ringing waveform without the extra capacitor (C_a), and checked for oscillating Ringing period (T_o). The red curve is the input current to the transformer and green curve is the output voltage of the transformer.

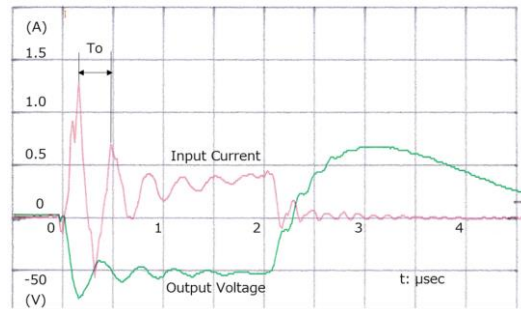

Figure 2(a). Wave form for control with no extra added capacitor

If the Ringing was caused by the oscillation of the inductance and the stray capacitance of the coil, the stray capacitance (C_s) of the coil should be calculated by equation (1).

$$C_s = T_o^2 / (4\pi^2 L) \quad (1)$$

With measured Ringing period T_o (410 nsec), and measured primary coil inductance L (0.418mH), then our calculated stray capacitance C_s (10.1866pF) is calculated from equation (1).

There were two extra added capacitors with different capacitance (C_a) that were connected to the primary coil. Figure 2(b) shows Ringing period T_b ($C_a=50$ pF) and Figure 2(c) shows Ringing period T_c ($C_a=880$ pF) in nsec.

Figure 2(b) shows the Ringing waveform with the first extra capacitor (C_a), and checked for oscillating Ringing period (T_b). As before, the red curve is the input current to the transformer and green curve is the output voltage of the transformer.

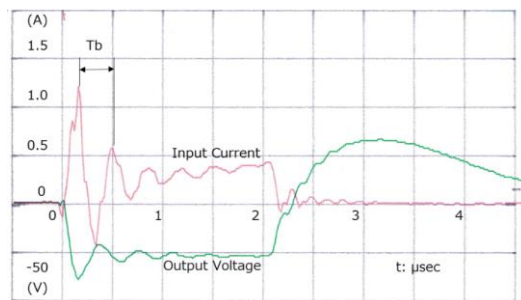

Figure 2(b). Wave form for extra added capacitor. ($C_a = 50$ pF)

Figure 2(c) shows the Ringing waveform with the second extra capacitor (C_a), and checked for oscillating Ringing period (T_c). As before, the red curve is the input current to the transformer and green curve is the output voltage of the transformer.

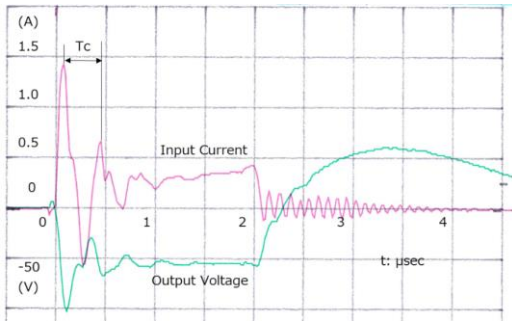

Figure 2(c). Wave form for extra added capacitor. ($C_a = 880\text{pF}$)

EXPERIMENTAL SUMMARY and CONSIDERATION

Table 1 shows the relation with the capacitance (C_a in pF) of the extra capacity, the measured Ringing period (T_{measured} in nsec), and the estimated Ringing period ($T_{\text{calculated}}$ in nsec) calculated by equation (2).

$$T_{\text{calculated}} = 2\pi\sqrt{L(C_s + C_a)} \quad (2)$$

Where, the measured inductance L (0.418mH) of the primary coil, stray capacitance C_s (10.1866pF) of the coil derived from equation (1), and C_a (pF) extra added capacitance are known.

Table 1. Experimental & Calculated Result

Test	C_a (pF)	T_{measured} (nsec)	$T_{\text{calculated}}$ (nsec)
T_o (control)	0 ($C_s=10\text{pF}$)	410	410
T_b	50	338	995
T_c	880	375	3868

Figure 2(b), Figure 2(c) and Table 1 show almost no difference in Ringing period between the wave form of control and extra added capacitance.

On the other hand, the capacitance of MOS-transistor (C_{ds}) is not negligible value, as it is measured ($C_{ds} = 1.88\text{nF}$). If Ringing oscillation was caused by (C_{ds}) and the inductance of transformer (L), the period of Ringing should be $T_e = 5.57\ \mu\text{sec}$ calculated by equation (2). But Ringing is not concerned to the capacitance of MOS-transistor, because (T_e) is too large compared with the measured value ($T_o = 410\text{nsec}$).

Table 2. I: Calculation and I: Measurement at Peak of Ringing in Fig 2(a)

Current Wave	T (μsec)	$I_{\text{calculated}}$ (mA)	Comparison	I_{measured} (mA)
Peak 1	0.163	19.5	<<<	1,303
Peak 2	0.313	37.3	>	-566
Peak 3	0.488	52.8	<	697
Peak 4	0.675	80.7	>	0

According to Fig 2(a) and summarized in Table 2, the 1st peak current of Ringing is very high, the 2nd peak current is very low and

reached negative region. It means strong positive and negative EMF is induced alternately. The EMF function of equation (13) in reference (2) proposed by the author (O. Ide) is expressed by an infinite series of the time differential function of the magnetic flux. If this EMF function is true, there should be a variety of positive and negative EMF induced in the short moment just after the MOS is turned on. The 2nd term of the function is Faraday's EMF and the 3rd term of it is the main positive EMF. But the 4th term of it is negative EMF, the 5th term is positive again and so on. The author (O. Ide) supposes Ringing might be caused by higher terms of the EMF function. But this conclusion needs more research.

Taking attention to a Ringing of input current (red) around $t = 2.5 \sim 3.0\ \mu\text{sec}$ on Figure 2 (c), a wave form of increasing amplitude is observed. This phenomenon means the magnetic energy of transformer was increased in the short moment, although a MOS-transistor was turned off. The Ringing wave form like this is on Figure (5) in [5]. Furthermore a same kind of wave form of input current had often been seen in Tesla coils the author made. The cause of Ringing like this might be a Parametric Resonance in [4], [5].

CONCLUSION

The hypothesis of Ringing is caused by oscillation of inductance and not the stray capacitance. There should be a different reason of it. According to the result, the first peak of Ringing current looks too high, the 2nd peak of Ringing is too low, compared with the calculation.

The author (O. Ide) presumes the Ringing noise is caused by positive and negative EMF induced in by higher terms of EMF equation (13) in [2].

Acknowledgement

The author thanks the support and excellent comments of Franklin Amador to present this paper.

REFERENCES

- Ide, O., "Increased voltage phenomenon in a resonance circuit of unconventional magnetic configuration," *J.Appl.Phys.*, 77(11), (1995), pp6015-6020
- Ide, O., "Possibility of existence of non-linear electromotive force(EMF)," *NASA/CP-2000-21029*, (July 2000), pp705-719
- Ide, O., "A Hyper-Efficient Inverter Driven by Positive EMF in Combination with Transient Phenomenon," *SPESIF 2011, Physics Procedia*, Vol.20, (2011), pp420-434
- Franklin D. Amador, Horst Eckardt., "Simulation of a Parametric Resonance Circuit," <http://www.aias.us>, March 30, 2012."
- Horst Eckardt, Bernhard Foltz., "Simulation of a Parametric Oscillator Circuit, Part2," <http://www.aias.us>, May 28, 2013.
- Ide, O., "INVERTER DRIVING SYSTEM"; US Patent 8873262; 2014