

Experimental verification and theoretical explanation of the Osamu Ide experiment

Kurt Arenhold*

Dipl.-Phys., Munich

Horst Eckardt†

Alpha Institute for Advanced Studies (AIAS) and
Unified Physics Institute of Technology (UPITEC)

June 23, 2015

Abstract

In a series of papers Osamu Ide has experimentally shown that by applying an electric pulse on a transformer, a current appears that does not have a counterpart in classical electrodynamics. This behaviour has been verified by own experiments. There is a short pulse of about $2 \mu\text{s}$ and an onset of current, which is significantly larger than the current to be expected from the circuit according to ordinary circuit theory. This non-classical behaviour can be explained by a model based on Einstein-Cartan-Evans (ECE) theory which incorporates elements of general relativity. From this model, a differential equation for the vector potential emerges which depends on the so-called spin connection, a phenomenon of spacetime structure. By using a parametrized model for the spin connection, the experimental curves for the on-set of current can be explained very well. This might be a mechanism of energy transfer from the non-empty vacuum.

Keywords: serial resonance circuit; transformer; initial current; Einstein Cartan Evans (ECE) field theory; simulation model.

1 Introduction

Progress in science is driven by experimental findings that cannot be explained by theory developed so far. Non-ordinary effects of electrodynamics are difficult to find, the standard Maxwell-Heaviside equations work well at the very most. Experimenters who assert to have found unusual effects either did not publish these findings or did not apply scientific methods so that nearly no verifiable facts are available in this respect. For example all reconstructions of Tesla's patents failed in producing "energy from spacetime" and at most showed well known effects of electrodynamics. Fortunately three papers [1]- [3] of Osamu Ide appeared that give enough details for verifying the effects he found. The first

*e-mail: rlohdaen@gmx.de

†e-mail: mail@horst-eckardt.de

author of this paper built a circuit for executing the first two Ide experiments and proved that it is repeatable and reproducible. In order to avoid parasitic effects like static voltages, he developed a circuit which is free of a ground connection.

The results gave us enough confidence that the observed effects are real. A novel explanation should be tried because Maxwell-Heaviside theory (in the form of circuit theory) gives no explanation at all. It was realized that most of a suitable theory had already been worked out in connection with the Bedini device [4]. Members of the AIAS institute did this already in 2007 when it was believed that this device could be used to obtain energy from spacetime. This hope has scattered but the details worked out for the theory appeared to be reusable to a large extent. Bedini used an "energizer coil" and an inductors were also used in Ide's experiments. So we refer to paper 94 of the UFT series [4] for a detailed derivation and use the results directly.

In the next section we describe the experiments carried out. In the third section the ECE-based theory is shortly recapitulated and a numerical explanation model is presented that is able to describe all effects found by Ide. Some discussion in chapter four concludes the paper.

2 Experimental findings

In three papers [1]- [3] Osamu Ide and co-workers have described anomalies found in the switch-on behaviour of inverter circuits which essentially consist of a transformer with a capacity in the primary path. The circuit used by Ide is shown in Fig. 1. Ide found a noise which is called ringing and is a damped oscillation observed when the MOS-transistor of the driving circuit is turned on and off. Ide tried to show that this ringing is not an effect of the parasitic capacitance of the transformer. After the short ringing period a current appears like a positive back-EMF which gives rise to an irregular overshooting of circuit current. In contrast, the standard behaviour of the circuit is caused by the onset of coil current which is slowed down by the counter-induced voltage in the coil. In the ordinary physical description of circuits there is no such term. An additional amount of energy might be obtained with this increased rising behaviour.

Ide's experimental setup is shown in Fig. 1. He used a ferrite core in the transformer. He supposed that the sharp current spike has no connection to the inductance of the transformer or the gate capacitance of driving MOS-FET. This "ringing" seems to be a fluctuation of zero point energy. It happens just after switch-on in less than two microseconds, so it is difficult to eliminate. But it might be related to EMF of more than the third current derivative in the regular equation.

In the very short period just after the MOS-FET is turned on, a small negative current pulse occurred in addition to a larger positive pulse. He found this phenomenon in every experiment he did. However no modern inverter elements can be used to investigate the effect because it is "smoothed away" and the transformer parts showing the ringing are not directly accessible to measurements. In his third paper, Osamu Ide utilized the irregular current after the spike to gather additional energy from the circuit.

For our own experiments it was first necessary to exclude any parasitic

ground effects because these can distort high-frequency components in measured signals significantly. Therefore a circuit was designed to decouple the whole apparatus from ground (Fig. 2). The oscilloscope was the only connection to ground. The required DC voltage of up to 72 V was obtained from a two capacitor banks, charged by two power supplies and then connected in series. Several types of inductors were used to investigate the irregular current effect. The effect was only detectable in coils with iron core, not with air cores or cores from paramagnetic materials. This lets us suppose that the effect is connected with the existence of free magnetic moments in materials, i.e. with magnetizable materials. About 100 experiment runs were carried out showing this result in a repeatable way.

The result of a significant sample is graphed in Fig. 3. The voltage switched on by a MOS-FET is shown to be very stable in the presented range of 900 μs . The current exhibits a strong positive peak at the beginning of less than 5 μs . The sampling rate was not high enough to resolve this peak more precisely. All effects of Osamu Ide could be reproduced. In Fig. 3 the experimental curve is decomposed into four contributions:

1. The linear current increase due to the classical circuit behaviour:

$$U = L \frac{dI}{dt}, \quad (1)$$

constant voltage U means a linear increase in current I of an inductance L :

$$I_0 = \frac{U}{L} t. \quad (2)$$

2. A peak at the switch pulse (ringing),
3. An initial effect of type

$$I = I_1 (1 - \exp(-\alpha t)) \quad (3)$$

going into saturation after about hundred microseconds, using parameters I_1 (saturation current) and α (damping factor),

4. A constant current offset I_2 ,

The parameters were (in arbitrary units, currents close to Ampere):

$$\frac{U}{L} = 0.000038 \quad (4)$$

$$I_1 = 0.036 \quad (5)$$

$$I_2 = 0.007 \quad (6)$$

$$\alpha = 0.0068 \quad (7)$$

For this measurement we used an ordinary 150 W transformer - with a 1.2 MOhm resistor as load, which should be negligible. We assume the start spike to be an effect of oscillation within the coil powered by the high frequency components of the switching of the voltage, which we already reduced by introducing the 2 x 160 Ohm resistors at the gate of the Power-FET to slow down

the switching effect a bit. But the loading of the parasitic capacitor in the coil is still visible, and cannot be removed completely. Ide found this spike having positive and negative values while we could reduce it to a positive spike only. By introducing and varying an additional capacity in the circuit he showed that the origin of the spike is not the parasitic capacitance of the coil. Therefore we included it into the theoretical considerations. It should be noted, however, that the parasitic capacitance is not expected to behave like a regular capacitance. Therefore the changes in the ringing period by adding an external capacity (as Ide did) are nearly unpredictable. The more important effect is the third item listed above.

3 Explanation by ECE theory

In the preceding section we described four effects from which at least one is not explainable by standard circuit theory. The characteristics of these effects should be derivable from an alternative theory to give a satisfactory explanation. We use the ECE theory [5]- [6], a unified field theory which is able to describe spacetime effects not present in standard electrodynamics [7]- [8]. Besides the electromagnetic field \mathbf{E} , the magnetic field \mathbf{B} , the scalar potential ϕ and the vector potential \mathbf{A} , there are the so-called spin connections ω_0 (scalar spin connection) and $\boldsymbol{\omega}$ (vector spin connection), which describe curvature and torsion of space. The spin connections are not included in Maxwell-Heaviside theory, therefore ECE theory is able to describe more effects than standard theory. However, it has been shown that in case of smooth potentials and fields, the equations of ECE theory can be reduced to those of Maxwell-Heaviside theory. This may be the reason why standard theory works so well although the fields are highly non-constant which is equivalent to torsion effects in ECE theory.

In the Ide experiments the unexpected effects arise after a sharp pulse which means a discontinuity (or non-differentiable point) in time-dependence of some fields. Therefore we expect non-standard effects around this pulse. The pulse is an enforced change of the electric field which is connected to the current in the coil wire by Ohm's law:

$$\mathbf{J} = \sigma \mathbf{E}_{\text{driving}} \quad (8)$$

where \mathbf{J} is the current density, σ the conductivity and $\mathbf{E}_{\text{driving}}$ is a "driving" electric field. The electromagnetic behaviour of the coil is described by the Maxwell-like ECE equations. Such a case has been investigated in great detail for the Bedini machine [4] as explained in the introductory section. The ECE-like equations can be rewritten by using the scalar and vector potential and a driving term of the electric field. The coordinate system is cylindrical to give a simple representation of a coil geometry. The wire current then flows in angular φ direction. The vector potential has two components A_φ and A_r where r is the radial coordinate. The system is translational symmetric in Z direction so that there is no dependence on this coordinate.

The equations being relevant for the coil are given by (1.55), (1.56) and (1.60) in [4]:

$$\ddot{A}_r + \dot{\omega}_0 A_r + \omega_0 \dot{A}_r = -(\dot{E}_r)_{\text{driving}}, \quad (9)$$

$$\ddot{A}_\varphi + \dot{\omega}_0 A_\varphi + \omega_0 \dot{A}_\varphi = -(\dot{E}_\varphi)_{\text{driving}}, \quad (10)$$

$$\omega_0 = -\frac{\dot{A}_r}{A_r}, \quad (11)$$

where the dot denotes the time derivative. An electric scalar potential has been neglected. The driving terms are enforced changes of the electric field which represents the switch-on pulse in our case very well. As has been explained in [4], the spin connection defined by Eq.(11) can be inserted into Eq.(9), however, due to the derivation of the equations, both are not independent from each other, and this leads to

$$(\dot{E}_r)_{\text{driving}} = 0 \quad (12)$$

which can be verified by insertion. Obviously Eq.(12) is a compatibility relation. In our case it means that there is no radial driving term possible, only one in angular direction which is the switch-on pulse. We have to solve Eq.(10) for a predefined ω_0 . The current of the switch-on effect then can be obtained from the classical field relation

$$E_{\varphi,\text{on}} = -\dot{A}_\varphi \quad (13)$$

and Ohm's law

$$\mathbf{J}_{\text{on}} = \sigma \mathbf{E}_{\varphi,\text{on}}. \quad (14)$$

The spin connection has to describe the spacetime effects at switch-on time and can be interpreted as a non-classical vacuum interaction which is conveyed by the magnetizable material. Since a pulse is observed, we define a model function that strongly oscillates at the beginning and then asymptotically changes into a constant:

$$\omega_0 = \omega_1 - \omega_2 \sin(\omega_3 t) e^{-\alpha t}. \quad (15)$$

ω_2 is an amplitude parameter, ω_3 an oscillation frequency and α a damping constant. ω_1 is the asymptotic value because the exponential function forces the second term to zero for large t . This model function is graphed in Fig. 4, together with its time derivative (in arbitrary units). In addition, the function for the driving term was realized as a step function:

$$(\dot{E}_\varphi)_{\text{driving}} = \begin{cases} f_1 & \text{if } t < t_0 \\ f_2 & \text{if } t \geq t_0 \end{cases} \quad (16)$$

This was necessary instead of using a delta function which is not manageable numerically. The differential equation (10) then has been solved numerically with the given function $\omega_0(t)$. Since A_φ represents the observed current according to Eqs. (13, 14), an initial value $\dot{A}_\varphi = 0$ is appropriate. The initial value of A_φ has been chosen as an additional adjustable parameter. The results for a suitable parameter set are graphed in Fig. 5, together with the experimental curve. Quite perfect coincidence is found. The initial range is shown in Fig. 6 with an enlarged time scale. It can be seen that even the pulse height is met by theory. The pulse width is smaller than in the measurement but, as can be seen, the sampling rate was not sufficient to resolve the spike in full detail (our equipment was not able to do that).

4 Discussion

The asymptotic current behaviour of a constant ω_0 can be derived from Eq.(10). If ω_0 is independent of time, the time derivative vanishes, and with definition

$$C_\varphi = \dot{A}_\varphi \quad (17)$$

Eq.(10) reads

$$\dot{C}_\varphi + \omega_0 C_\varphi = -f_2 \quad (18)$$

where C_φ stands for the current as described above. This equation has the analytical solution

$$C_\varphi(t) = C_0 e^{-\omega_0 t} - \frac{f_2}{\omega_0}. \quad (19)$$

With $C_0 < 0$, $f_2 < 0$, $\omega_0 > 0$ this describes the exponential term in Fig. 4. The term is a consequence of a constant spin connection. The oscillatory part obviously is only required to explain the initial pulse. This may then be connected with effects of a parametric oscillator [9]- [10]. However the driving term cannot be restricted to the initial pulse, a small portion f_2 has to be retained for times $t > t_0$. This may be either an artifact of modeling, or an effect of vacuum interaction which is not fully understood yet. The constant current offset could be shown to be an effect of the constant part ω_1 of the spin connection (15).

In total we have verified the experimental findings of Osamu Ide. All non-standard effects could be explained by a model of ECE theory. The initial pulse may have an origin in spacetime effects or not, it can be described by the theory as well as the negative exponential rise of the current in the first microseconds after its appearance.

5 Acknowledgments

The colleagues of the Munich Group are thanked for many interesting discussions.

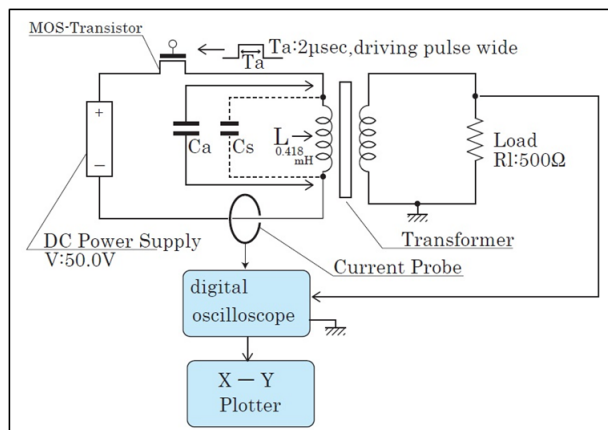

Figure 1: Transformer circuit of Osamu Ide [1].

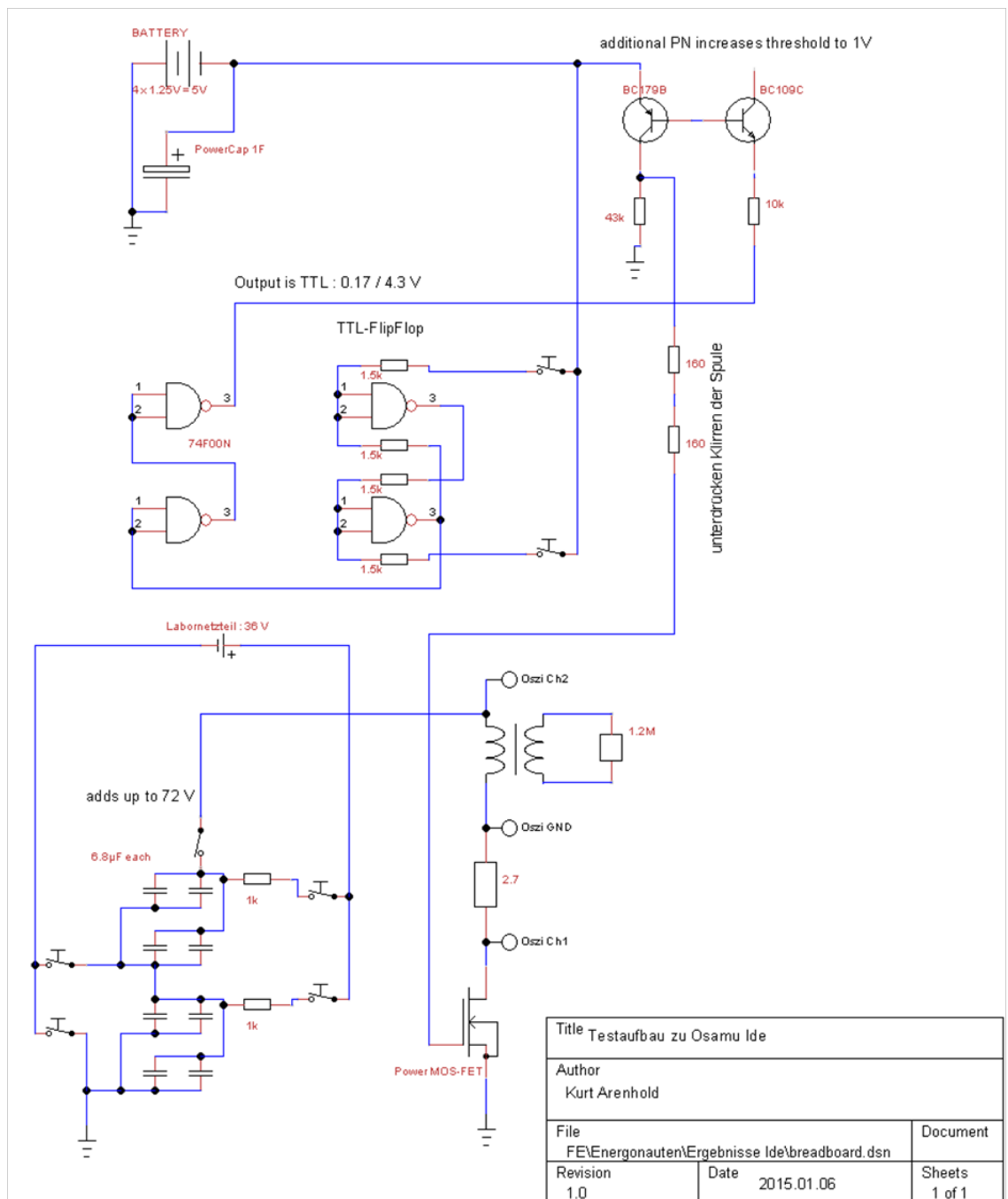

Figure 2: Test circuit, ground connection was at osci GND. Ground symbols: only formally / in-circuit only.

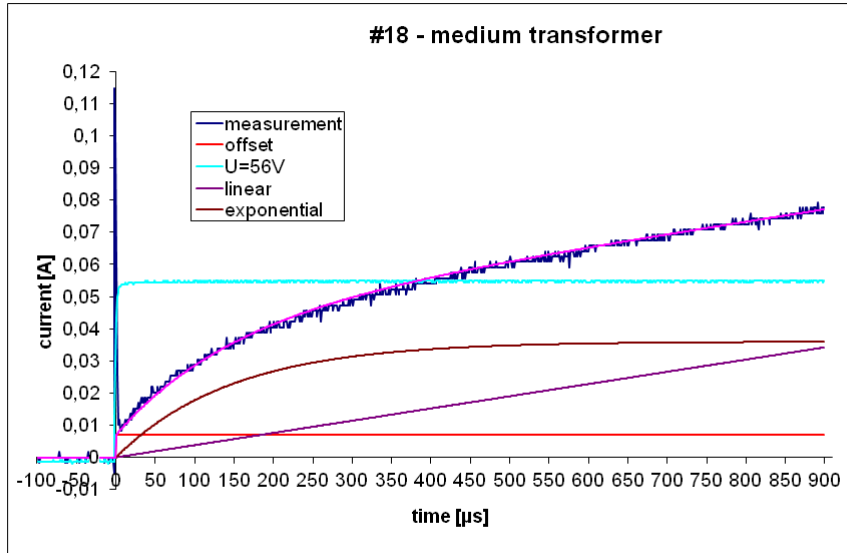

Figure 3: Measurement of transformer with ferrit core, this work. Curve was fitted with constant, linear and exponential constituents.

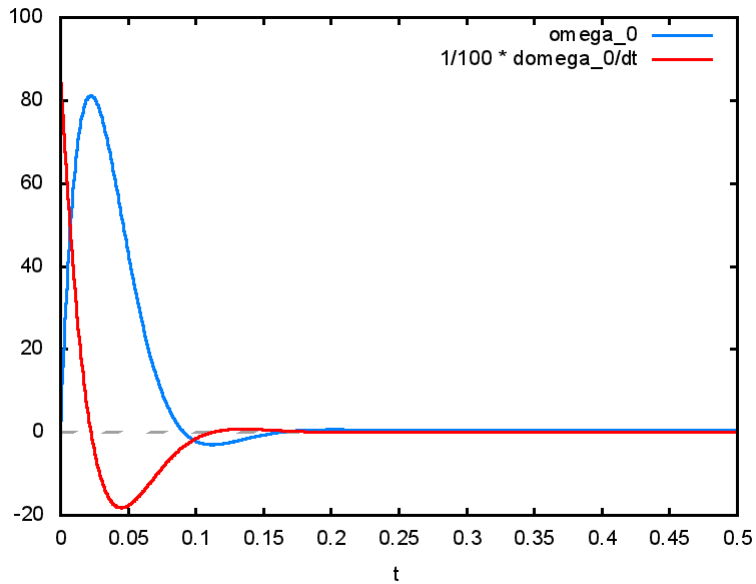

Figure 4: Model spin connection $\omega_0(t)$ and its derivative.

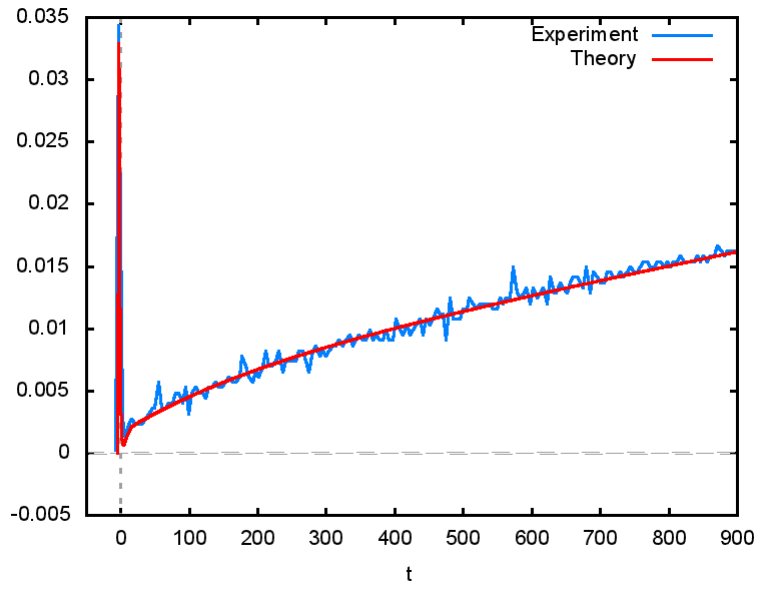

Figure 5: Comparison of experiment (this work) with theory (ECE model).

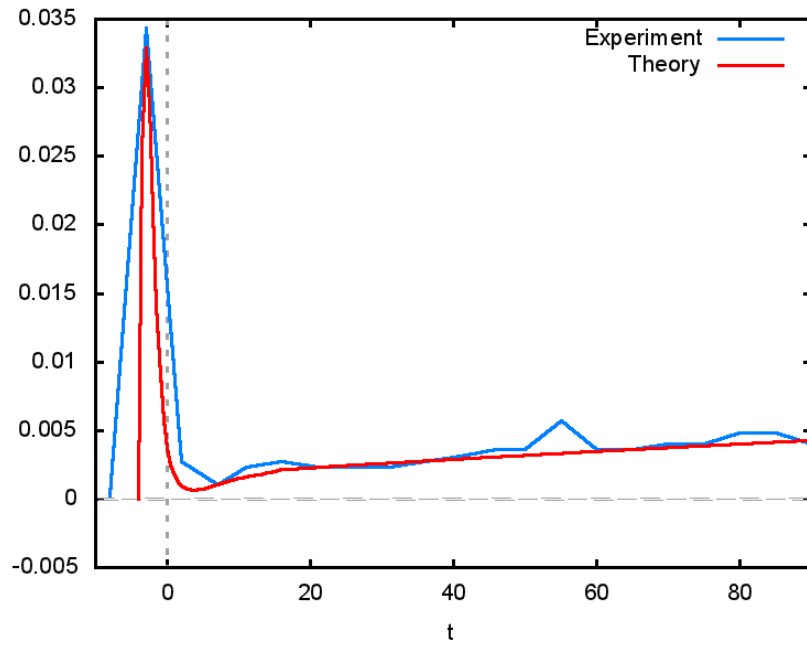

Figure 6: Comparison of experiment (this work) with theory (ECE model), expanded initial range.

References

- [1] O. Ide, T. Yamazaki, T. Maeza, T. Funabashi, and H. Ichinose, "Consideration of the Cause of Inverter Noise called Ringing", presented at 249th ACS National Meeting & Exposition in Denver March 24, 2015, Division of Energy & Fuels, ENFL 351.
- [2] O. Ide, T. Yamazaki, T. Maeza, T. Funabashi, and H. Ichinose, "Anomalous Rising of Input Current Induced in the Transformer of Inverter", presented at 249th ACS National Meeting & Exposition in Denver March 24, 2015, Division of Energy & Fuels, ENFL 350.
- [3] O. Ide, "Characteristics of DC Power Output from an Inverter Driven by Sharp Spike Pulse", presented at 249th ACS National Meeting & Exposition in Denver March 24, 2015, Division of Energy & Fuels, ENFL 352.
- [4] M. W. Evans, H. Eckardt, C. Hubbard, J. Shelburne, "Spin Connection Resonance in the Bedini Machine", UFT paper 94 of www.aias.us, 2008.
- [5] M. W. Evans, "Generally Covariant Unified Field Theory" (Abramis, Suffolk, 2005 onwards), volumes one to five, also available on www.aias.us as single articles.
- [6] H. Eckardt, "ECE Engineering Model (Slide set)", UFT paper 303 of www.aias.us, 2014.
- [7] H. Eckardt, "How do space energy devices work?", www.aias.us, 2007.
- [8] H. Eckardt, "Devices for Space-Time Resonance Based on ECE Theory", www.aias.us, 2008.
- [9] F. D. Amador, H. Eckardt., "Simulation of a Parametric Resonance Circuit", <http://www.aias.us>, March 30, 2012.
- [10] H. Eckardt, B. Foltz., "Simulation of a Parametric Oscillator Circuit, Part2", <http://www.aias.us>, May 28, 2013.